

# SM 20 TECHNICAL DATA

INDEX	PAGE	PAGE	
INTRODUCTION	1	CONFIGURATION INFORMATION	6
EQ CURVES	1	REAR PANEL CONNECTORS	7
INPUT & OUTPUT MODULES	2	NOMINAL LEVEL DIAGRAM	7
BLOCK DIAGRAMS	3-5	TYPICAL SPECIFICATIONS	8
ARCHITECT'S SPECIFICATION	6	DIMENSIONS AND WEIGHTS	8

## INTRODUCTION

The Soundcraft SM20 is a professional monitor console offering from 20 mono sends to 7 stereo, plus 6 mono sends, for use in touring of fixed applications. A compact frame reduces on-stage space requirements and the modular design allows for future expansion and ease of maintenance.

- 32, 40, 48 AND 56 INPUT FRAMES**
**4-BAND EQ PLUS VARIABLE HPF**
- 20 MONO OUTPUTS OR 7 STEREO PLUS 6 MONO OUTPUTS**
**FLEXIBLE SUB-GROUPING**
- COMPACT RUGGED FRAME**
**8 MUTE GROUPS**
- REMOTE CONTROL OF BSS VARICURVE**

## TYPICAL EQ CURVES

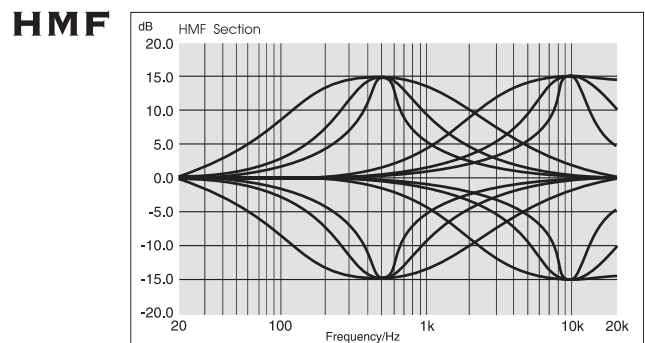
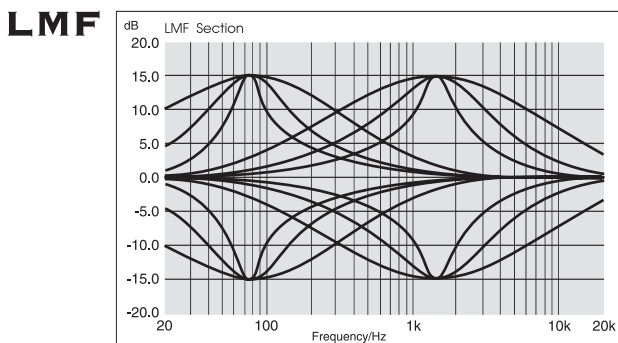
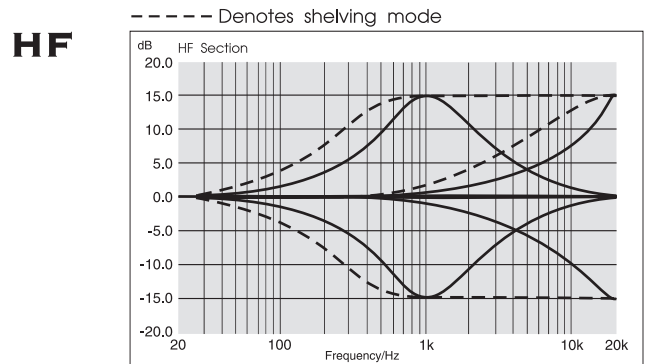
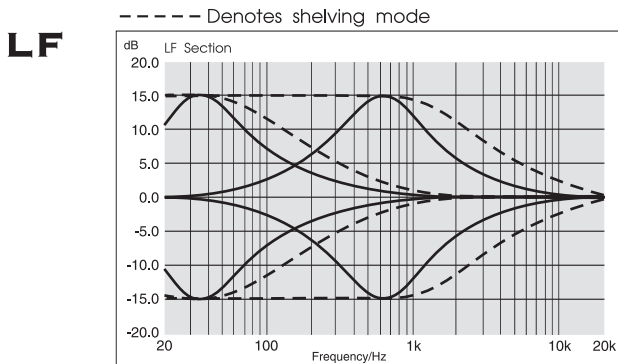

### INPUT MODULE



### OUTPUT MODULE



### MASTER MODULE

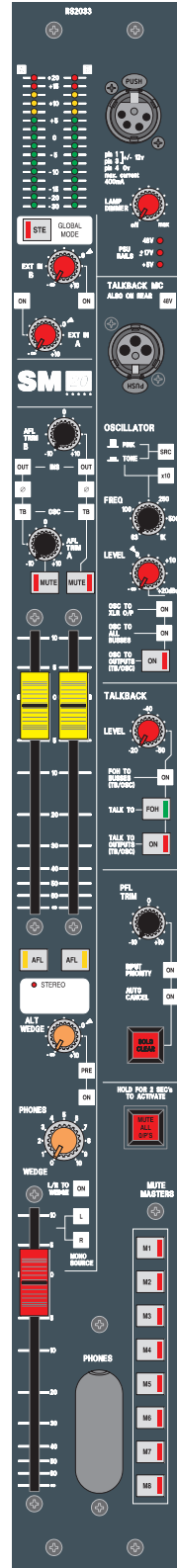

**INPUT MODULE**

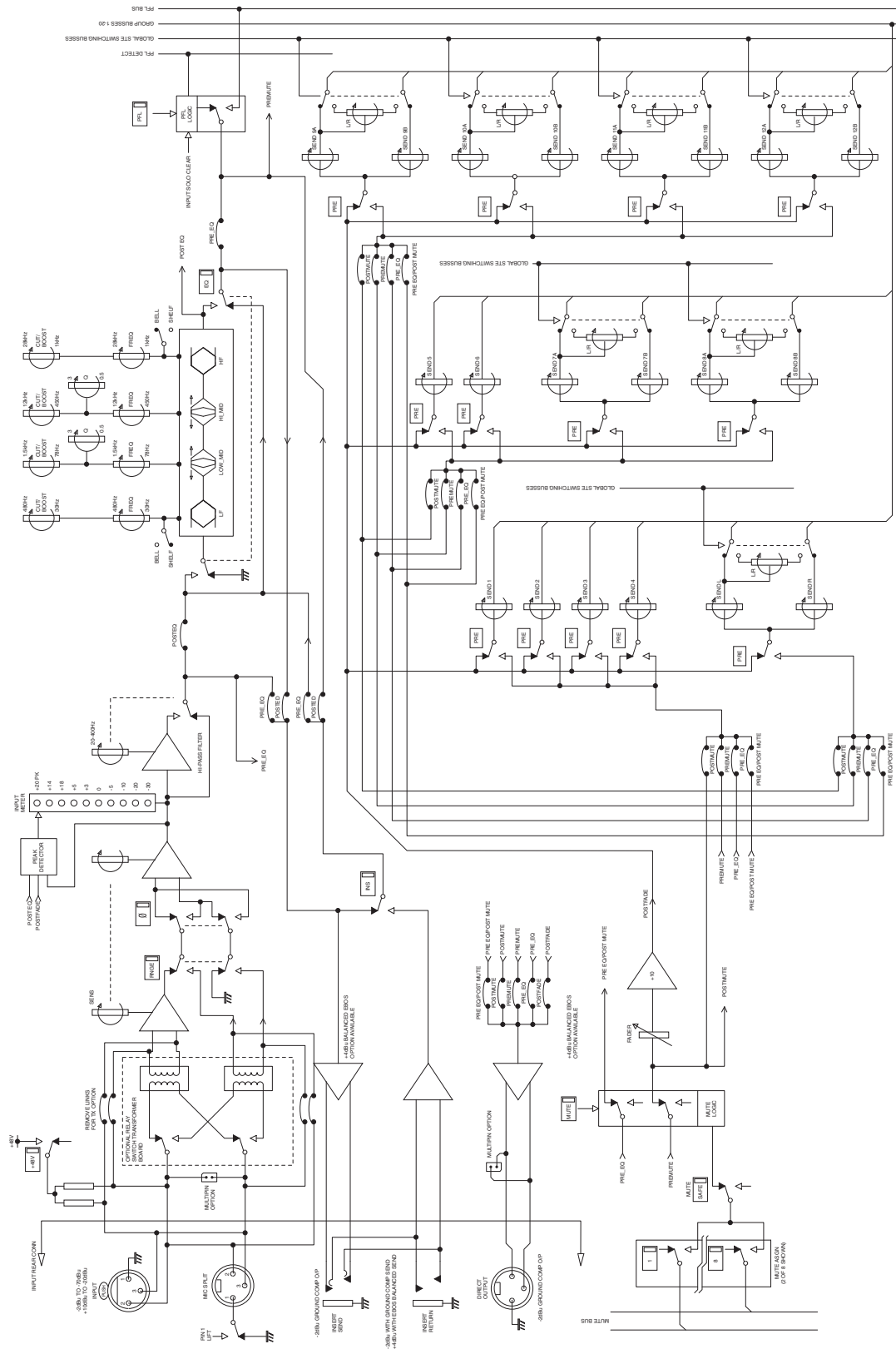

**OUTPUT MODULE**

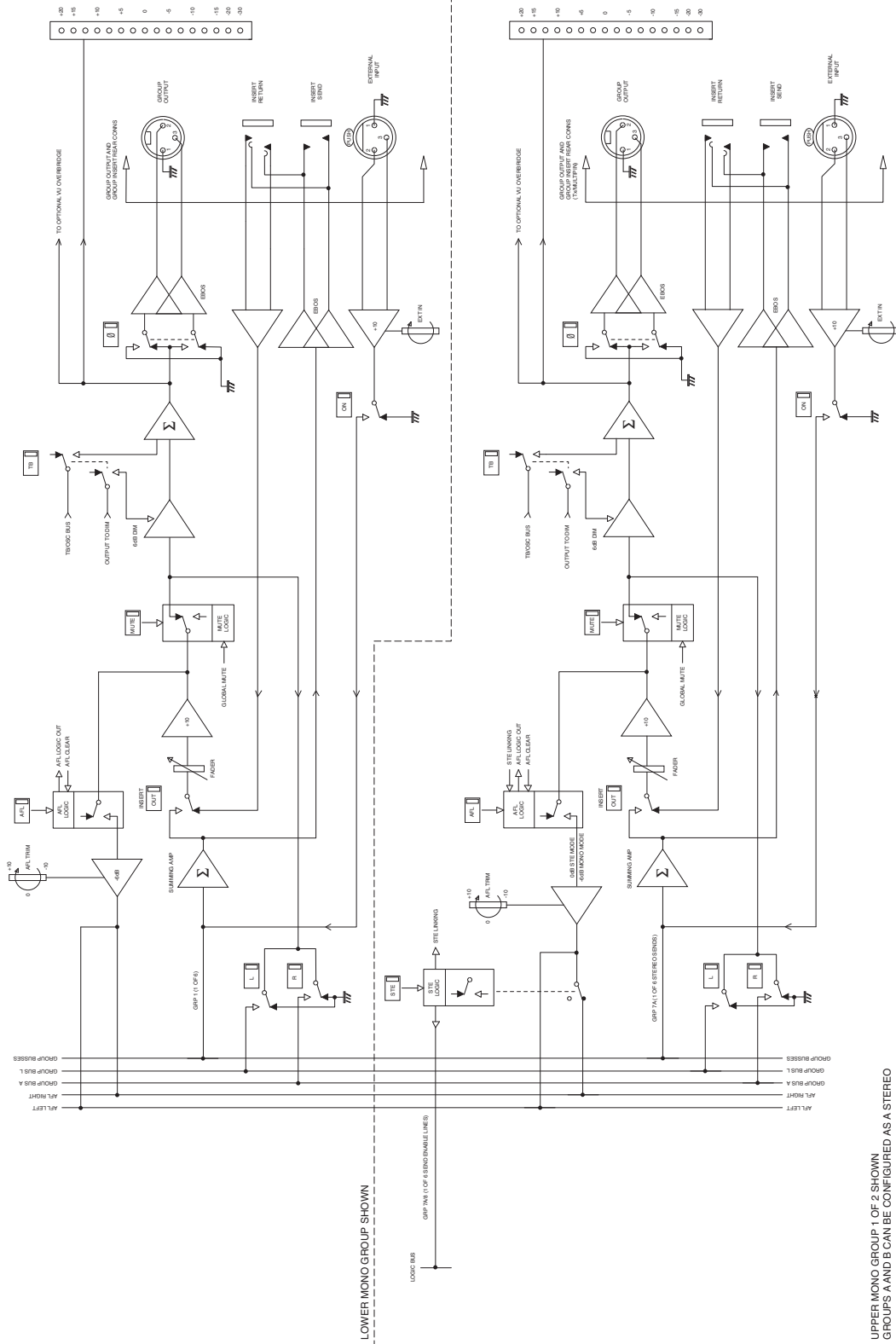

UPPER MONO GROUP 1 OF 2 SHOWN  
GROUPS A AND B CAN BE CONFIGURED AS A STEREO



### MASTER MODULE

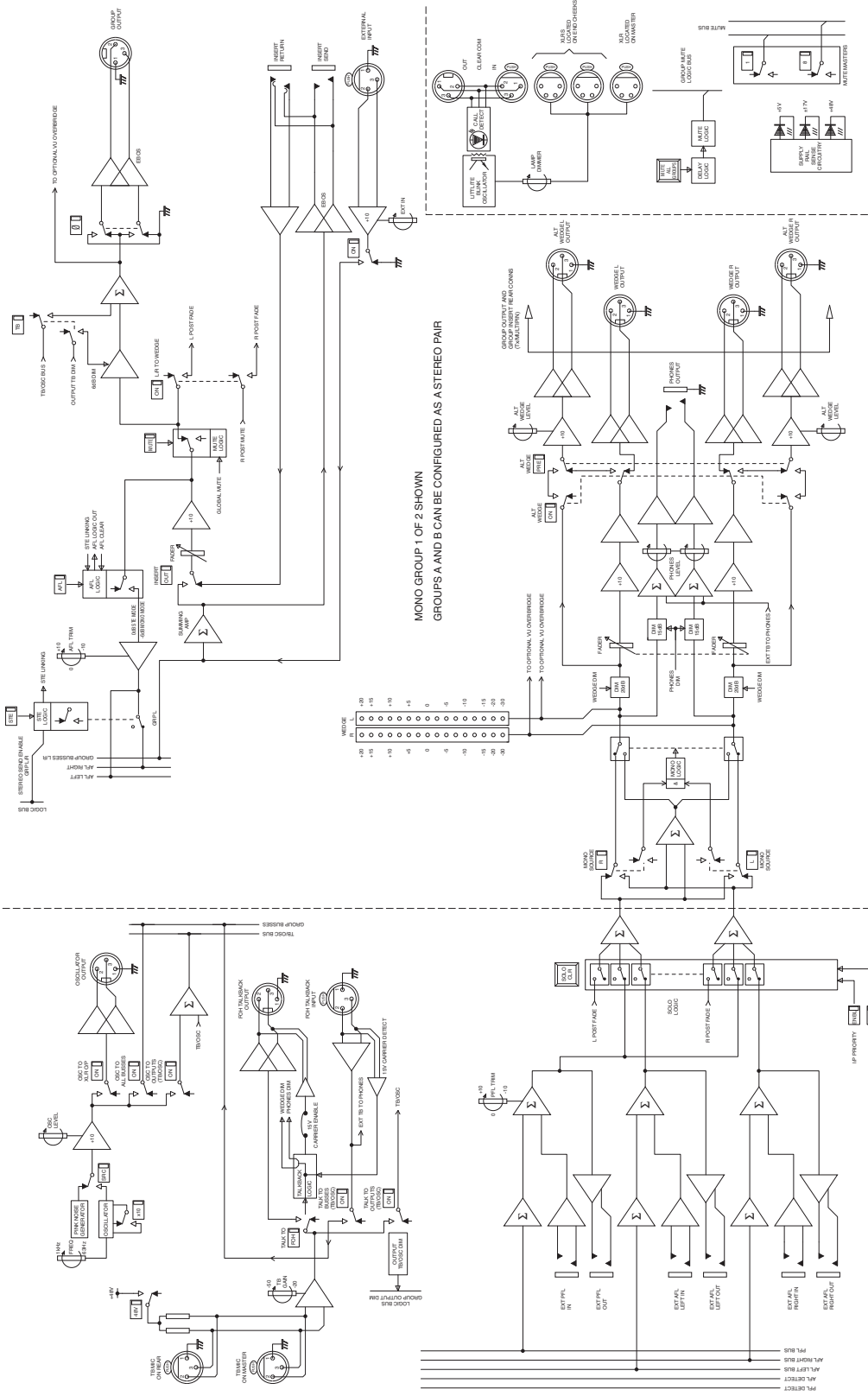

**ARCHITECT’S SPECIFICATIONS**

The Mixing Console shall be of a fully modular construction available in 32, 40, 48 and 56 input frames. The mixing console shall provide a combination of between 20 mono and up to 7 stereo and 6 mono sends, depending on global switching. As standard, the console shall be provided with 6 Triple Group Output modules and 1 double-width Master module. All frames will be supplied with a separate CPS800 19 inch rack-mounting Power Supply. There shall be an optional VU Output Meterbridge for all sizes except the 32ch.

The Input Module shall have the following features; an electronically balanced low impedance input via an XLR socket with parallel connection to a passive mic split output, continuously variable gain giving a sensitivity range of -2dBu to -70dBu (high gain range) and -20dBu to +10dBu for high level inputs, switchable 48V phantom power, a variable 20-400Hz high-pass filter, phase reverse switch, by-passable 4-band sweep equaliser 1kHz to 20kHz (HF) 450Hz to 12kHz (HMF), 60Hz-1.5kHz (LMF) and 12Hz to 350Hz (LF). The Q of the two mid bands shall be variable from 0.5-3.0 and the HF and LF bands shall be switchable bell/shelving. All bands shall have a cut and boost of 15dB (centre detented). 20 sends shall be provided via 6 single pots and 7 dual concentrics, with individual pre/post fader switching (in pairs on dual concentrics) with internal selection to pre or post mute/EQ. The dual concentric sends act either as two mono level controls or stereo level and pan, determined by global switching. Illuminated Solo and Mute switches shall control the main signal path and allow the prefade signal to be monitored at all times. An 10 segment pre-EQ LED meter shall be provided, plus a separate Peak LED to indicate internal levels within 6dB of clipping. Eight mute assign switches shall be fitted, with an additional Safe switch for removing a channel from one of the eight mute groups. There shall be a link-selectable pre or post EQ insert point using separate balanced send and return jacks. All connectors shall be integral with the main module.

The Output Module shall contain 3 identical output sections as follows; 100mm fader with 16-segment peak-reading LED meter, balanced by-passable insert point, illuminated Mute switch and AFL switch, Group LR routing switches, Talkback switch and phase reverse. An external line input shall be provided to allow console linking, with rotary level control and On switch. An AFL trim control shall be provided with a range of +/-10dB. External inputs shall be connected via balanced XLRs; main outputs shall use electronically balanced XLRs with a transformer option. A global mono/stereo mode switch allows the upper two output sections to be used as a stereo pair, with automatic linked stereo AFL, and will switch the input send pots between mono and stereo operation. The AFL switches shall be able to send a midi signal to an external BSS Varicurve system, to allow the remote selection of EQ pages on the BSS Remote.

The Master Module shall have a dual Grp L/R output section with identical facilities to those of the upper Output module, but not the Grp LR routing switches. The Master module shall also contain a Talkback mic socket with routing to internal busses, FOH and external output, variable frequency oscillator/pink noise generator, Solo Clear, Input Priority and Intercancel selection with PFL trim control, stereo/mono engineer’s wedge fader, main/alternate wedge output selection, independent headphone socket and level control , 8 mute group master switches and 2 x 16-segment LED L and R master meters.

A lamp dimmer control shall vary the brightness of three console mounted 4-pin XLR lamp sockets; one on each side cheek and one on the master module.

The dimensions and specifications shall be as published elsewhere in this information. The console shall be the Soundcraft SM20.

**CONFIGURATION INFORMATION**

SM20 32 channel	RW5422	SM20 Mono Input Module	RS2031
SM20 40 channel	RW5541	SM20 Output Module	RS2032
SM20 48 channel	RW5542	SM20 Master Module	RS2033
SM20 56 channel	RW5543	SM20 Blank Module	PH1454-01
(Above consoles supplied with 1xCPS800 PSU)		Spare CPS800 Power Supply	RW8024
SM20 40 ch Vu meterbridge	RW5550	Spare User Manual	ZM0226
SM20 48 ch Vu meterbridge	RW5551	Technical Manual	ZM0227
SM20 56 ch Vu meterbridge	RW5552	Littlite 18” 4pin XLR	JB0155



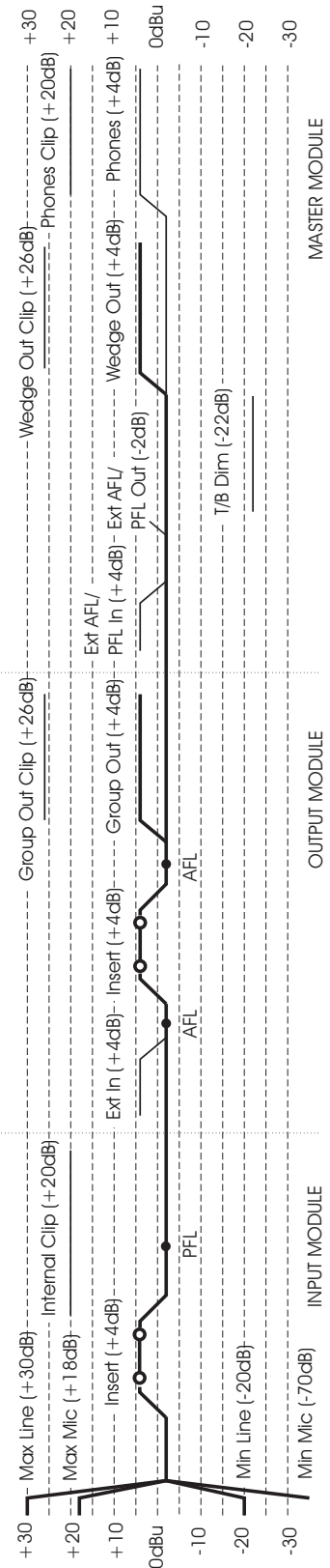
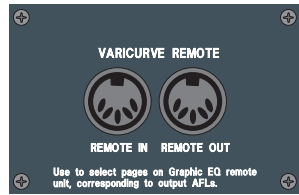
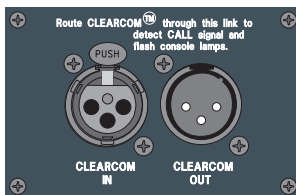
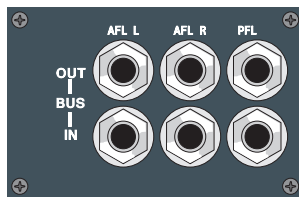
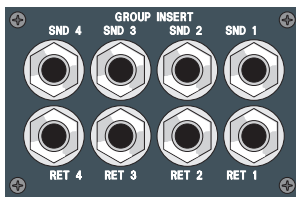
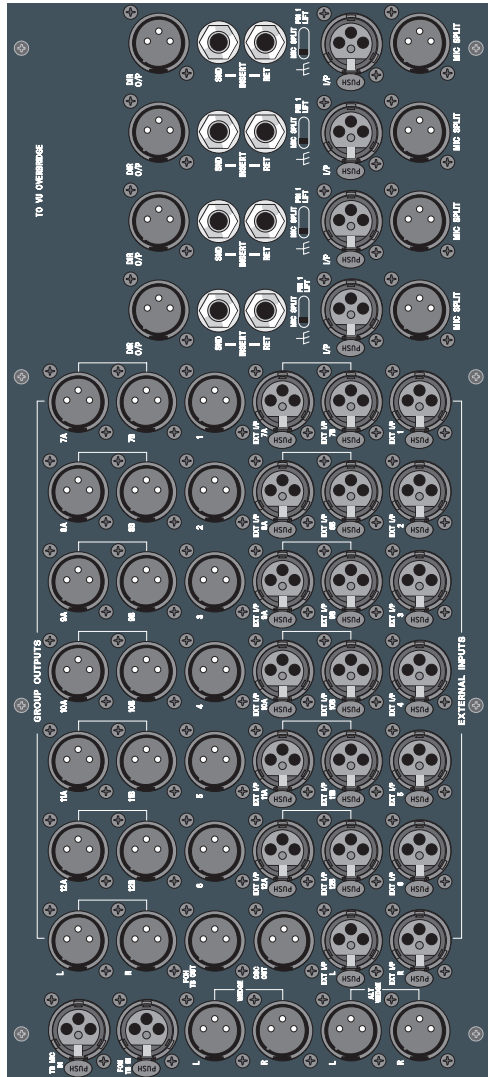

# SM 20 TECHNICAL DATA

## SM20 SPECIFICATIONS

### Frequency Response

XLR Input to any Output 20Hz - 20kHz, +0/-0.5dB

### Total Harmonic Distortion

All measurements at +20dBu  
Line In to Group or Mix Out

Less than 0.005%  
@ 1kHz  
Less than 0.025%  
@ 10kHz

### Noise

22Hz - 22kHz bandwidth, unweighted  
Mic input Equivalent Input Noise

Less than  
-127.5dBu (200Ω source)

Group Output Noise

Less than -80dBu  
(40 ch routed)

Mix Output Noise

Less than -80dBu  
(40 ch routed)

### Crosstalk

All measurements at 1kHz

Input Channel Muting  
Input Channel Send Pot Isolation  
Group Fader Isolation  
Group to Group Crosstalk  
Group to XLR Crosstalk

Greater than 100dB  
Greater than 100dB  
Greater than 95dB  
Less than -90dB  
Less than -90dB

### Input and Output Impedances

Input  
All Insert Sends  
All Insert Returns  
2kΩ balanced  
Less than 75Ω balanced  
Greater than 10kΩ  
balanced  
Outputs  
Less than 75Ω balanced

### Input/Output Capability

Maximum Input Level  
All Insert Sends  
All Insert Returns  
All Balanced Outputs  
Headphone Output  
+30dBu  
+20dBu into 2kΩ  
+26dBu  
+26dBu into 1kΩ  
+20dBu into 600Ω  
1W into 8Ω

### Input and Output Levels

Input Sensitivity (XLR)  
Input Insert Send/Return  
Output Insert Send/Return  
Outputs  
-2dBu to -70dBu,  
+10dBu to -20dBu  
-2dBu nominal  
+4dBu nominal  
+4dBu for 0VU

## DIMENSIONS

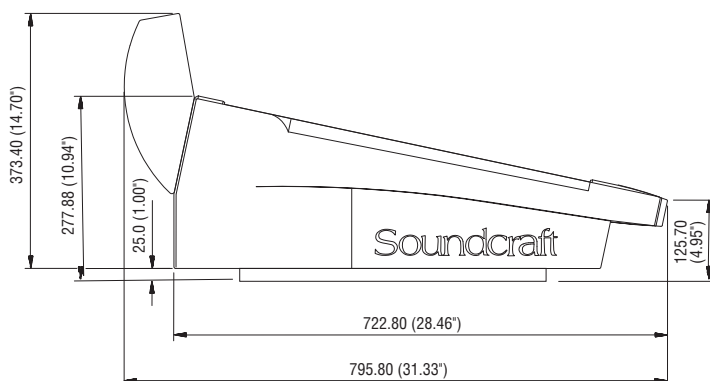

Console	Overall Width
32ch frame	1366mm (53.8")
40ch frame	1620mm (63.78")
48ch frame	1874mm (73.78")
56ch frame	2128mm (83.78")



Harman International Industries Limited, Cranborne House, Cranborne Road, Potters Bar, Hertfordshire EN6 3 JN, UK  
Tel: +44 (0) 1707 665000 Fax: +44 (0) 1707 660482 Sales Fax: +44 (0) 1707 660742 Email: info@soundcraft.com http://www.soundcraft.com

Soundcraft US, Harman Pro North America Inc., Air Park Business Center 12, 1449 Donelson Pike, Nashville, TN 37217, USA.

Tel: 1-615-360-0471 Fax: 1-615-360-0273